

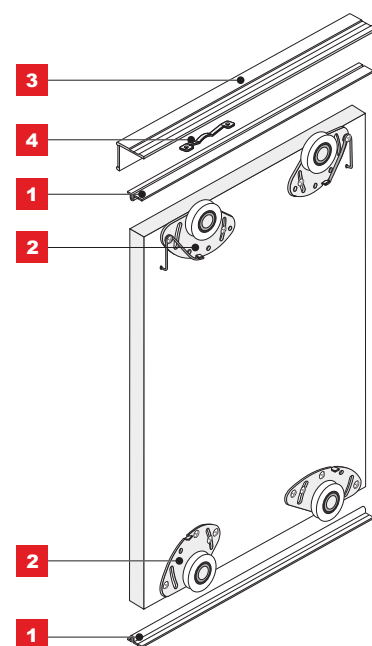

MICRA



Single track sliding doors with bottom carriage system



CHARACTERISTICS

▶ Application	Sliding doors
▶ Track	Single
▶ Carriage system	Bottom
▶ Top guide	Ball bearing carriage
▶ Bottom guide	Ball bearing carriage (load bearing)
▶ Construction	Board
▶ Filling	Board 16-50 mm
▶ Max. door load	50 kg
▶ Max. handle length	n/a
▶ Max. track length	3000 mm
▶ Textile door stops	n/a
▶ Anti-dust brushes	n/a
▶ Sales programme	Components can be purchased separately
▶ Decorative profile programme	n/a

USAGE

- ▶ Built-in furniture (walk-in wardrobes, wardrobes, attics)

Basic system components

Track **MICRA**



CODE	COLOUR	LENGTH (mm)	COLLECTIVE PACKAGING	PRICED PER	NET PRICE
01117	SILVER	1700	50	item	
01114	LIGHT BROWN	1700	50	item	
50233	RAW	1700	50	item	
01119	SILVER	2350	50	item	
01115	LIGHT BROWN	2350	50	item	
50235	RAW	2350	50	item	
01120	SILVER	3000	50	item	
01116	LIGHT BROWN	3000	50	item	
50236	RAW	3000	50	item	

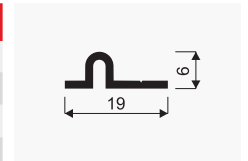

SET: MICRA C
(1 wing)



i Set contains 2 top guides, 2 bottom carriages, 2 springs and screws

CODE	COLLECTIVE PACKAGING	PRICED PER	NET PRICE
10199	50	set	

Angle section **K2-Decor**



DECOR

CODE	COLOUR	LENGTH (mm)	COLLECTIVE PACKAGING	PRICED PER	NET PRICE
00078	SILVER	1700	60	item	
00069	LIGHT BROWN	1700	60	item	
00079	SILVER	2350	60	item	
00070	LIGHT BROWN	2350	60	item	
00080	SILVER	3000	60	item	
00071	LIGHT BROWN	3000	60	item	

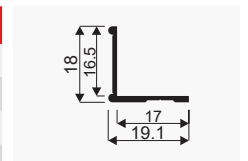

Stopper **MICRA C** with screws
(Set 2pcs)

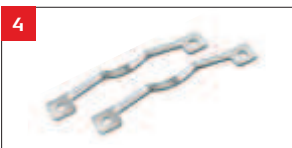

i Set contains 2 stoppers and 4 screws

CODE	COLLECTIVE PACKAGING	PRICED PER	NET PRICE
10231	500	set	

Countersunk screw **UNIX**

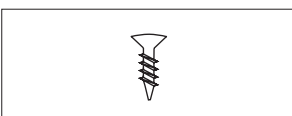

i Pack contains 100 screws Unix

CODE	DIMENSIONS (mm)	COLLECTIVE PACKAGING	PRICED PER	NET PRICE
20107	3 x 13	20	pack	

Silicone stoppers



i 1 strip contains 50 silicone stoppers

CODE	COLLECTIVE PACKAGING	PRICED PER	NET PRICE
20011	50	strip	

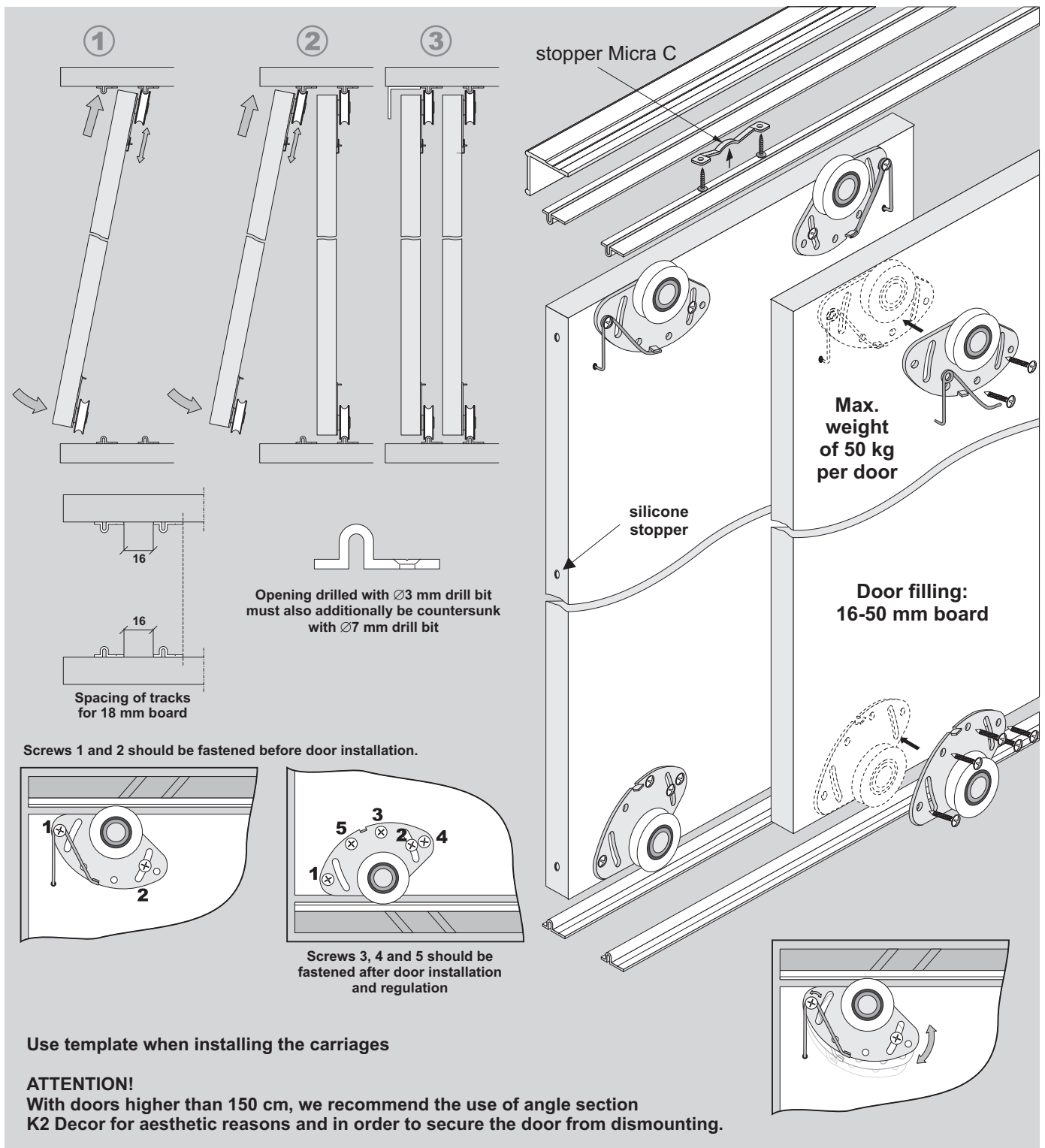

COMPONENTS

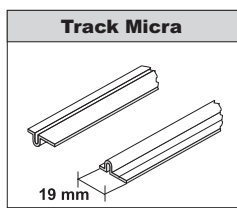

Length: 1.7 m, 2.35 m, 3.0 m

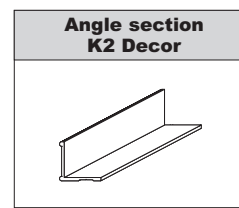
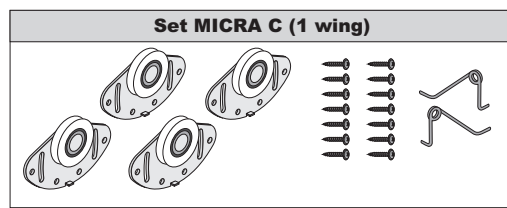

Length: 1.7 m, 2.35 m, 3.0 m

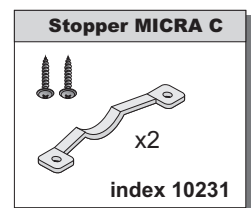



Dimensions of opening

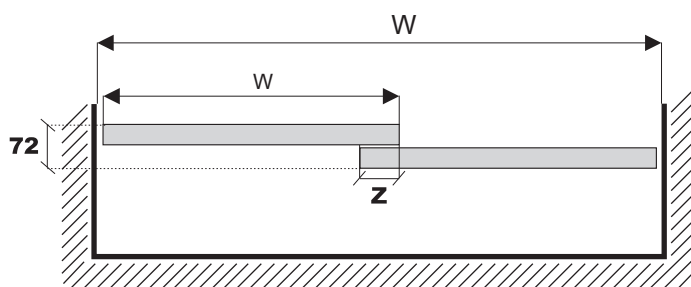
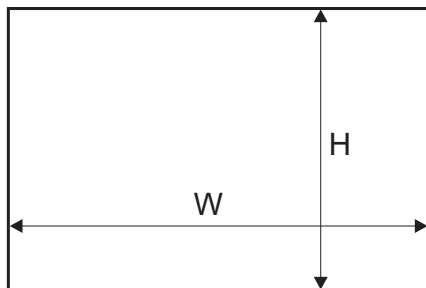

Door filling - #18 mm board

Door height	- h	$h = H - 13 \text{ mm}$
Board height (1 mm ABS edging)	- hb	$hb = h - 2 \text{ mm}$
Door width	- w	$w = (W + Z) : N$
Board width (1 mm ABS edging)	- wb	$wb = w - 2 \text{ mm}$

ATTENTION!
When cutting the board, you need to include the thickness of ABS edging. On our calculation 1 mm ABS edging was used.

Number of doors	- N	2	3	4	5
Total overlap	- Z	30 mm	60 mm	90 mm	120 mm

Visual design – 4 wings	
	$w = (W + 90) : 4$
	$w = (W : 2 + 30) : 2$

ATTENTION!

System Micra can be used in conjunction with any of SEVROLL's handle profiles suitable for 18 mm fillings.

Installation of stopper MICRA C

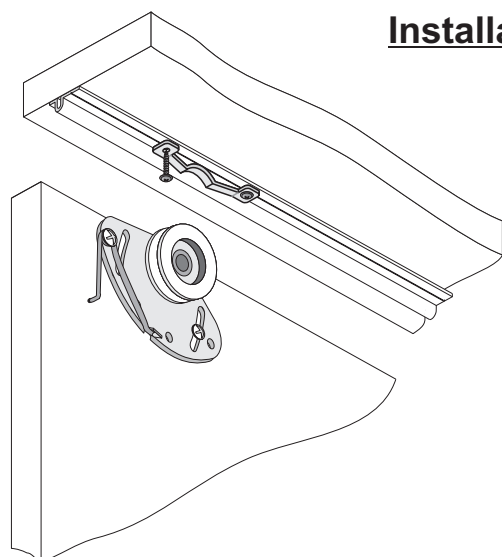

stopper installed on top track

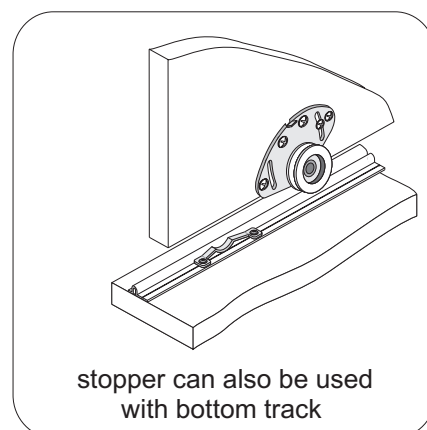

stopper can also be used with bottom track

ATTENTION!

Remove protective film from aluminium elements (handles, tracks, connectors, etc.) prior to cutting them to the desired size. Film removal will reveal quality issues (eg. scratches)